

**澳門特別行政區****REGIÃO ADMINISTRATIVA ESPECIAL  
DE MACAU****行政長官辦公室****GABINETE DO CHEFE DO EXECUTIVO****第 90/2014 號行政長官公告****Aviso do Chefe do Executivo n.º 90/2014**

中華人民共和國是國際海事組織的成員國及一九七四年十一月一日訂於倫敦的《國際海上人命安全公約》（下稱“公約”）的締約國；

Considerando que a República Popular da China é um Estado Membro da Organização Marítima Internacional e um Estado Contratante da Convenção Internacional para a Salvaguarda da Vida Humana no Mar, concluída em Londres em 1 de Novembro de 1974, adiante designada por Convenção;

國際海事組織海上安全委員會於一九九六年十二月五日對公約第II-2章作出修改，使國際耐火試驗程序應用規則在一九九八年七月一日以後成為公約下的強制性規定，並透過第MSC.61(67)號決議通過了《國際耐火試驗程序應用規則》；

Considerando igualmente que, em 5 de Dezembro de 1996, o Comité de Segurança Marítima da Organização Marítima Internacional procedeu a emendas ao capítulo II-2 da Convenção para tornar as disposições do Código Internacional dos Procedimentos para as Provas de Fogo obrigatórias, nos termos da Convenção, a partir de 1 de Julho de 1998, e que, através da resolução MSC.61(67), adoptou o Código Internacional dos Procedimentos para as Provas de Fogo;

中華人民共和國於一九九九年十二月十三日以照會通知聯合國秘書長，經修訂的公約自一九九九年十二月二十日起適用於澳門特別行政區；

Mais considerando que, a República Popular da China, por nota datada de 13 de Dezembro de 1999, notificou o Secretário-Geral das Nações Unidas sobre a aplicação da Convenção, tal como emendada, na Região Administrativa Especial de Macau, a partir de 20 de Dezembro de 1999;

基於此，行政長官根據澳門特別行政區第3/1999號法律第六條第一款的規定，命令公佈包含上指規則的第MSC.61(67)號決議的中文及英文文本。

O Chefe do Executivo manda publicar, nos termos do n.º 1 do artigo 6.º da Lei n.º 3/1999 da Região Administrativa Especial de Macau, a resolução MSC.61(67), que contém o referido Código, nos seus textos em línguas chinesa e inglesa.

二零一四年十一月七日發佈。

Promulgado em 7 de Novembro de 2014.

行政長官 崔世安

O Chefe do Executivo, *Chui Sai On*.

## MSC.61 (67) 號決議

(1996 年 12 月 5 日通過)

### 通過《國際耐火試驗程序應用規則》

海上安全委員會，

憶及《國際海事組織公約》關於本委員會職能的第 28 (b) 條，

認識到需要對經修訂的《1974 年國際海上人命安全公約》第 II-2 章要求的耐火試驗程序作強制應用，

注意到委員會據之通過《安全公約》第 II-2 章修正案的 MSC.57 (67) 號決議使《國際耐火試驗程序應用規則》(《FTP 規則》) 在 1998 年 7 月 1 日以後成為安全公約下的強制性要求，

在其第六十七次會議上審議了建議的《FTP 規則》文本，

1. 通過《國際耐火試驗程序應用規則》(《FTP 規則》)，其文本載於本決議的附件中；
2. 注意到按《安全公約》第 II-2 章的修正案，《FTP 規則》的修正案應按照該公約第 VIII 條關於適用於除第 I 章外的公約附件的修正程序的規定通過、生效和實施；
3. 要求秘書長把本決議和附件中的《FTP 規則》文本的核正無誤的副本轉發給本公約的所有締約政府；

4. 還要求秘書長把本決議和附件的副本轉發給非本公約締約政府的所有本組織會員。

## 附 件

### 國際耐火試驗程序應用規則

#### 目 錄

- 1 範圍
- 2 適用範圍
- 3 定義
- 4 試驗
  - 4.1 耐火試驗程序
  - 4.2 試驗室
  - 4.3 試驗報告
- 5 認可
  - 5.1 總則
  - 5.2 型式認可
  - 5.3 個案認可
- 6 可以不經試驗和/或認可就安裝的產品
- 7 等效方式或現代技術的採用
- 8 其他試驗程序的寬限期
- 9 參考文獻目錄

|        |                                          |
|--------|------------------------------------------|
| 附件 1   | 耐火試驗程序                                   |
|        | 前言                                       |
| 第 1 部分 | 不易燃性試驗                                   |
| 第 2 部分 | 煙和毒性測試                                   |
| 第 3 部分 | “A”、“B”和“F”級分隔試驗                         |
|        | 附錄 1 – “A”、“B”和“F”級分隔上的窗子<br>耐火試驗的補充散熱試驗 |
|        | 附錄 2 – 連續“B”級分隔                          |
| 第 4 部分 | 防火門控制系統試驗                                |
|        | 附錄 – 防火門控制系統耐火試驗程序                       |
| 第 5 部分 | 表面易燃性試驗                                  |
|        | 附錄 – 對結果的解釋                              |
| 第 6 部分 | 甲板底覆層試驗                                  |
| 第 7 部分 | 縱向支持織物和薄膜試驗                              |
| 第 8 部分 | 單面家具試驗                                   |
| 第 9 部分 | 床上用品試驗                                   |
| 附件 2   | 可以不經試驗和/或認可安裝的產品                         |
| 附件 3   | 其他耐火試驗程序的採用                              |

## 國際耐火試驗程序應用規則

### 1 範圍

1.1 本規則供主管機關和船旗國的有關當局在按照經修訂的《1974 年國際海上人命安全公約》的耐火安全要求對在懸掛其國旗的船舶上安裝的產品進行認可時採用。

1.2 試驗室在按本規則試驗和評估產品時應採用本規則。

### 2 適用範圍

2.1 本規則適用於要求按照本公約中提及的《耐火試驗程序規則》進行試驗、評估和認可的產品。

2.2 如果在本公約中以“……按《耐火試驗程序規則》”的術語提及本規則，則試驗產品應按第 4.1 款提及的適用的耐火試驗程序進行試驗。

2.3 如果在本公約中使用諸如“……且其暴露表面應具有低播焰性”之類的術語而僅提及產品的耐火性能，則試驗產品應按第 4.1 款提及的適用的耐火試驗程序進行試驗。

### 3 定義

3.1 “《耐火試驗程序規則》”係指在本公約第 II-2 章中作出定義的《耐火試驗程序應用規則》。

3.2 “試驗截止日期”係指可使用特定的試驗程序按本公約對任何產品進行試驗並對其進行認可的最後日期。

3.3 “認可截止日期”係指作為滿足本公約耐火安全要求的證據的其後認可為有效的最後日期。

3.4 “主管機關”係指船旗國政府。

3.5 “有關當局”係指由主管機關授權行使本規則所要求職責的組織。

3.6 “主管機關認可的試驗室”係指有關主管機關可以接受的試驗室。經有關主管機關同意，對於特定的認可，可以在個案的基礎上認可其他試驗室。

3.7 “本公約”係指經修正的《1974年國際海上人命安全公約》。

3.8 “標準耐火試驗”係指把樣品放入試驗爐內使其暴露於大約相當於標準時間－溫度曲線的溫度的試驗。

3.9 “標準時間－溫度曲線”係指由下列公式確定的時間－溫度曲線：

$$T = 345 \log_{10} (8t+1) + 20$$

式中：

T 為平均爐溫 (°C)

t 為時間 (分)。

## 4 試驗

### 4.1 耐火試驗程序

4.1.1 本規則附件 1 載有規定的試驗程序，除第 8 款規定者外，在對產品進行試驗以作為認可（包括重新認可）的基礎時應予採用。

4.1.2 試驗程序指明了試驗方法和接受與分類的標準。

## 4.2 試驗室

4.2.1 試驗應在有關主管機關認可的試驗室內進行。

4.2.2 在認可試驗室時，主管機關應考慮以下標準：

- .1 作為其業務的常規部分，該試驗室從事與適用部分規定的試驗相同或相似的檢查和試驗；
- .2 試驗室具備進行這些試驗和檢查所必需的儀器、設備、人員和校準的儀錶；和
- .3 試驗室不歸試驗產品的製造商、銷售商或供應商所有或控制。

4.2.3 試驗室應採用由有關當局檢查的質量控制系統。

## 4.3 試驗報告

4.3.1 試驗程序載明了試驗報告的規定內容。

4.3.2 一般而言，試驗報告的產權歸試驗的發起人所有。

## 5 認可

### 5.1 總則

5.1.1 主管機關應按其制定的認可程序通過採用型式認可程序（見第 5.2 款）或個案認可（見第 5.3 款）來認可產品。



5.1.2 主管機關可以授權有關當局代表其頒發認可。

5.1.3 申請認可者應具有使用作為申請基礎的試驗報告的法定權利（見第 4.3.2 款）。

5.1.4 主管機關可以要求對認可的產品標以特別的認可標誌。

5.1.5 在產品安裝到船上時認可應有效。如果一個產品在製造時獲得認可，但在產品安裝到船上時該認可已經過期，則只要從認可證書到期之日以來認可的標準沒有發生變化，該產品仍可作為認可材料安裝。

5.1.6 應向主管機關或有關當局申請認可。申請書至少應包括以下內容：

- .1 申請者和製造商的名稱和地址；
- .2 產品的名稱和商品名；
- .3 認可的具體品質；
- .4 產品的組裝和材料的圖紙或陳述以及，在適用時，其安裝和使用須知；和
- .5 耐火試驗報告。

5.1.7 對產品的任何重大改變都應使有關的認可不再有效。要取得新的認可，必須對產品重新進行試驗。

## 5.2 型式認可

5.2.1 型式認可證書的頒發和更新應以適用的耐火試驗的試驗報告為

基礎（見第 4 款）。

5.2.2 主管機關應要求生產商具有一套由有關當局檢查的質量控制系統，確保始終符合型式認可條件。或者，主管機關可以使用最終產品驗證程序，即在產品安裝到船上之前，由有關當局驗證產品符合型式認可證書。

5.2.3 型式認可證書的有效期從頒發之日起不得超過 5 年。

5.2.4 型式認可證書應至少包括以下內容：

- .1 產品的認別（名稱或商品名及陳述）；
- .2 產品的類別和任何使用限制；
- .3 生產商和申請者的名稱和地址；
- .4 試驗中採用的試驗方法；
- .5 對試驗報告和有關鑒定（包括發表日期、可能的檔案編號及試驗室的名稱和地址）的核實；
- .6 型式認可證書的頒發日期和可能編號；
- .7 證書的有效期；和
- .8 頒發機構（有關當局）的名稱及，如適用，授權。

5.2.5 一般而言，經過認可的產品可以安裝到懸掛作出認可的主管機關的國旗的船上作預定的使用。

### 5.3 個案認可

5.3.1 個案認可係指不使用型式認可證書而准許將產品安裝到特定的船上的認可。

5.3.2 就特定的船舶應用而言，主管機關可以採用適用的試驗程序對產品進行認可而不頒發型式認可證書。個案認可對特定船舶有效。

## 6 不經試驗和/或認可就可以安裝的產品

本規則附件 2 指明被視為符合本公約特定的耐火安全規則（如果有的話）並可以不經試驗和/或認可就安裝的產品組。

## 7 等效方法和現代技術的採用

7.1 為允許現代技術和產品的開發，主管機關可以根據本附則沒有具體提到但主管機關認為等效於本公約的適用的耐火安全要求的試驗和驗證，批准將產品安裝到船上。

7.2 主管機關應按本公約第 I/5 條把 7.1 款提及的認可通知本組織，並履行下述文件程序：

- .1 對於新產品和非常規產品：有關為什麼不能用現有試驗方法試驗這一特定產品的書面分析；
- .2 說明建議的替代試驗程序如何證明產品的性能符合公約的要求的書面分析；
- .3 對建議的替代程序與公約要求的程序進行比較的書面分析。

## 8 其他試驗程序的寬限期

8.1 本組織通過的最新試驗程序被認為是證明有關產品符合本公約

的適用耐火安全要求的最合適的程序。

8.2 雖有本規則其他部分的規定，主管機關在認可產品符合公約的耐火安全要求時，可以採用既定的、非本規則附件 1 所載者的試驗程序和接受標準，以允許有一個可行的寬限期使試驗室獲得試驗設備、產業界重新試驗其產品和主管機關提供必要的新的證書。對於此種其他試驗程序和接受標準，試驗截止日期和認可截止日期載於本規則的附件 3 中。

## 9 參考文獻

在本規則附件 1 第 1 至 9 部分提及了以下國際海事組織大會決議和國際標準組織的標準：

- .1 第 A.471 (XII) 號決議 — “確定縱向支持的織物和薄膜耐燃性的試驗方法建議書” ；
- .2 第 A.563 (14) 號決議 — “確定縱向支持的織物和薄膜耐燃性的試驗方法建議書的修正案 (A.471 (XII))” ；
- .3 第 A.652 (16) 號決議 — “單面家具的耐火試驗程序建議書” ；
- .4 第 A.653 (16) 號決議 — “艙壁、天花板和甲板塗層材料的表面易燃性的經改進的耐火試驗程序建議書” ；
- .5 第 A.687 (17) 號決議 — “甲板底覆層的點燃性耐火試驗程序” ；
- .6 第 A.688 (17) 決議 — “床上用品的點燃性的耐火試驗程

序” ；

- .7 第 A.753 (18) 決議 – “船上塑料管應用指南” ；
- .8 第 A.754 (18) 決議 – “ ‘A’ 、 ‘B’ 和 ‘F’ 級分隔耐火試驗建議書”
- .9 國際標準化組織 1182 : 1990 – “耐火試驗 – 建築材料 – 不易燃試驗” ；
- .10 國際標準化組織 1716 : 1973 – “建築材料 – 發熱能力確定” ；及
- .11 國際標準化組織 5659 : 1994 – “塑料 – 煙氣產生，第 2 部分：通過單室試驗確定光密度” 。

## 附錄 1

### 耐火試驗程序

#### 前言

- 1 本附件載有驗證產品符合適用要求所應使用的耐火試驗程序。對其他試驗程序，本規則第 8.2 段和附件 3 的規定應適用。
- 2 在提及本附件的試驗程序時應指出適用部分的編號（如在試驗報告和型式認可證書中）：  
  
    示例：如果按附件 1 第 2 部分和第 6 部分對甲板底覆層進行了試驗，則應提及為：“國際海事組織 FTPC 第 2 和 6 部分”。
- 3 一些產品或其部件需按多個試驗程序進行試驗。為此，在本附件的一些部分提及到其他部分。這種提及僅供參考，適用的指南應在公約的有關要求中查找。
- 4 對於不經試驗和/或認可就可以安裝的產品，參閱本規則的附件 2。

## 第 1 部分 – 不易燃性試驗

### 1 適用範圍

1.1 在要求一種材料為不易燃材料時，應按本部分確定。

1.2 如果一種材料通過了第 2 節規定的試驗，則應視為“不易燃”材料，即使它由無機物和有機物的混合物組成亦然。

### 2 耐火試驗程序

2.1 應按國際標準化組織 1182:1990 標準中的試驗程序對不易燃性進行驗證，但應滿足下列所有標準而不是該標準的附件 A：“評估標準”：

- .1 按國際標準化組織 1182 第 8.1.2 計算出的燃燒爐熱電偶平均溫升不超過 30°C；
- .2 按國際標準化組織 1182 第 8.1.2 計算出的表面熱電偶平均溫升不超過 30°C；
- .3 按國際標準化組織 1182 第 8.2.2 計算出的平均持續燃燒時間不超過 10 秒；
- .4 按國際標準化組織 1182 第 8.3 計算出的平均質量損失不超過 50%。

2.2 試驗報告應包括以下信息：

- .1 試驗機構的名稱；
- .2 材料製造商的名稱；

- .3 材料的提供日期和試驗日期；
- .4 材料的名稱或認別；
- .5 對材料的陳述；
- .6 材料的密度；
- .7 對樣品的陳述；
- .8 試驗方法；
- .9 包括所有觀測數據在內的試驗結果；
- .10 按上述第 2.1 款規定的試驗標準對材料進行標定。



## 第 2 部分 – 煙和毒性試驗

### 1 適用範圍

在要求一種材料在高溫時不會產生過量的煙和有毒性產物或不會造成有毒危害時，該材料應符合本部分的要求。

### 2 耐火試驗程序

#### 2.1 總則

煙生成試驗應按國際標準化組織 5659:1994 標準第 2 部分和本規則本部分所述的附加試驗程序進行。為按照這一標準進行試驗，必要時應對國際標準化組織標準的安排和程序加以修改。

#### 2.2 試驗樣品

應按第 A.653 (16)、A.687 (17)、A.753 (18) 號決議所述的做法律準備試驗樣品。對於電纜，只需對有最大絕緣厚度的樣品進行試驗。

#### 2.3 試驗條件

在試驗期間對樣品的輻照度應保持恆定。應對三個樣品每一者在以下條件下試驗：

- .1 有引導火焰，輻照度為  $25\text{kW/m}^2$ ；
- .2 無引導火焰，輻照度為  $25\text{kW/m}^2$ ；及
- .3 無引導火焰，輻照度為  $50\text{kW/m}^2$ ；

## 2.4 試驗時間

試驗應至少持續 10 分鐘。如果在 10 分鐘的暴露期間未能達到最低光透射值，試驗應再持續 10 分鐘。

## 2.5 試驗結果

2.5.1 在試驗期間應至少每隔 5 秒記錄一次按下式確定的煙光比密度 ( $D_s$ ):

$$D_s = (V / (A * L)) * \log_{10} (I_0 / I)$$

其中：

V = 容器的總體積 ( $m^3$ )

A = 樣品的暴露面積 ( $m^2$ )

L = 煙氣測量的光程 (m)

$I_0$  = 試驗前的光度

I = 試驗期間的光度 (被煙吸收後)。

2.5.2 在測量毒性時，應在第二個或第三個樣品在各每一試驗條件下試驗期間，在達到最大煙的光比密度時的 3 分鐘內從容器的幾何中心取煙樣。有毒氣體的濃度應以占容器體積的百萬分值 (ppm) 來確定。

## 2.6 分類衡准

### 2.6.1 煙

應計算出在每一試驗條件下的三種試驗的  $D_s$  最大值的平均值 ( $D_m$ )。

- 1 用於艙壁表面、襯料或天花板的材料： $D_m$  在所有試驗條件下均不超過 200；

- .2 用於甲板底覆層的材料：Dm 在所有試驗條件下均不超過 400；
- .3 用於地板覆層的材料：Dm 在所有試驗條件下均不超過 500；和
- .4 塑料管和電纜：Dm 在所有試驗條件下均不得超過 400。

#### 2.6.2 毒性

在每一試驗條件下所量測的煙濃度均不得超過以下限值：

|                 |          |                 |         |
|-----------------|----------|-----------------|---------|
| CO              | 1450 ppm | HBr             | 600 ppm |
| HCl             | 600 ppm  | HCN             | 140 ppm |
| HF              | 600 ppm  | SO <sub>2</sub> | 120 ppm |
| NO <sub>x</sub> | 350 ppm  |                 |         |

#### 2.7 試驗報告

試驗報告應包含以下信息：

- .1 材料的類型，即表面塗料、地板覆層、甲板底覆層、管子，等等；
- .2 材料的商品名；
- .3 對材料的陳述；
- .4 樣品的結構；
- .5 材料製造商的名稱和地址；
- .6 在每種加熱和引燃條件下的 Dm 值；

- .7 有毒氣體的濃度（ppm），如適用；
- .8 按第 2.6 款作出的評定；
- .9 試驗室的名稱和地址；以及
- .10 試驗日期

### 3 附加要求

- 3.1 本附件第 5 部分也適用於在暴露的內表面上使用的油漆、地板覆蓋物、清漆和其他塗料。
- 3.2 本附件第 6 部分也適用甲板基層敷料。

### 第 3 部分 – “A”、“B” 和 “F” 級分隔試驗

#### 1 適用範圍

在要求產品（如甲板、艙壁、門、天花板、襯板、窗、擋火閘、管弄和電纜路徑部分）為 “A” 或 “B” 或 “F” 級分隔時，他們應符合本部分的要求。

#### 2 耐火試驗程序

2.1 產品應按第 A.754（18）號決議規定的耐火試驗程序進行試驗和評估。該決議在其附錄裏也載有窗子、擋火閘和管弄的試驗程序。

#### 2.2 樣品尺寸

2.2.1 對於本規則來說，第 A.754（18）號決議附件的 2.1.1、2.4.1 和 2.7.1 段的第一句話應由以下文字代替：

“試樣的最小總尺寸，包括頂部、底部和垂直邊緣的周長細節，為 2,440mm 寬和 2,500mm 高，但在 1998 年 12 月 31 日前，試驗可採用最小總尺寸為 2,440mm 高和暴露表面為 4.65m<sup>2</sup> 的試樣。以此種較小試樣的試驗為基礎的認可的截止日期為 2003 年 12 月 31 日。”

2.2.2 對於本規則來說，第 A.754（18）號決議附件的 2.2.1、2.5.1 和 2.8.1 段的第一句話應由以下文字代替：

“試樣的最小總尺寸，包括所有邊緣的周長細節，為 2,440mm 寬和 3,040mm 長，但在 1998 年 12 月 31 日前，試驗可採用最小總尺寸為 2,440mm 長和暴露表面 4.65m<sup>2</sup> 的試樣。以此種較小

試樣的試驗為基礎的認可的截止日期為 2003 年 12 月 31 日。”

2.2.3 樣品的尺寸應在試驗報告中寫明。

2.3 在要求對通過窗子的散熱加以限制時，可按本部分的附錄 1 對窗組件進行試驗和評估。

2.4 在要求天花板或襯板為連續“B”級天花板或襯板時，可按本部分的附錄 2 進行試驗和評估。

### 3 附加要求

3.1 “B”級結構的完整性應通過採用不易燃材料做到。不要求樣品結構中使用的粘合劑具有不易燃性；但是，對於本規則來說，它們應具有低播焰性。

3.2 在“B”級分隔板連接處為防止震動或噪音傳播而放置的材料應具有低播焰性並應與使用它們的“B”級分隔一起進行耐火試驗。但是，如果這些材料對於支持不易燃的“B”級結構或達到要求的完整性是必要的，它們應為不易燃材料。

3.3 裝在艙壁甲板以上並需同時滿足防火保護和水密要求的門和開門，應符合公約中對它們所在分隔的消防要求。裝在艙壁甲板下的水密門不要求隔熱。

### 4 其他說明

4.1 用於“A”和“B”級分隔的材料的不易燃性應按第 1 部分進行驗證。

4.2 當在“A”和“B”級分隔內允許使用易燃鑲面時，如果有此要求，則這種鑲面的低播焰性應按第 5 部分進行驗證。

## 附錄 1

### “A”、“B”和“F”級分隔上的 窗子的耐火試驗的補充散熱試驗

#### 1 範圍

1.1 本附錄規定了測量通過窗子的熱通量的程序，作為對窗子限制散熱從而防止火的擴散並使逃生通道能在窗子附近通過的能力作出定性的基礎。

1.2 本程序為選擇性要求，主管機關可以對船舶特定區域的窗子要求這一程序。

#### 2 試驗程序

2.1 應使用下文所述的附加儀器按第 A.754 (18) 號決議對窗子進行試驗。

2.2 “窗子”一詞包括窗子、舷窗和某一耐火分隔區為採光或觀察目的提供的任何其他裝有玻璃的開口。“耐火分隔”一詞包括艙壁和門。

#### 3 附加儀器

3.1 附加儀器由按限定視域校準的限定視域總熱量通量計構成，用以指示入射熱通量。通量計應為水冷却結構，並能夠測量從 0 到  $60\text{kW/m}^2$  的熱通量。通量計應至少每年比照標準儀器校準一次。

3.2 通量計應垂直於試驗窗子的中心放置，使通量計的視域中心與窗子的中心重合（見圖）。通量計與窗子間的距離應大於 0.5m，使熱通量計的視域恰好包括部分窗框。但是，通量計離窗子不應超過 2.5m。位於窗子外側的通量計看到的邊界與窗框的尺寸不應超過通量計在樣品表面看到的總寬度的 10%。這一點應以通量計的限制視角和通量計與樣品間的距離來計算。

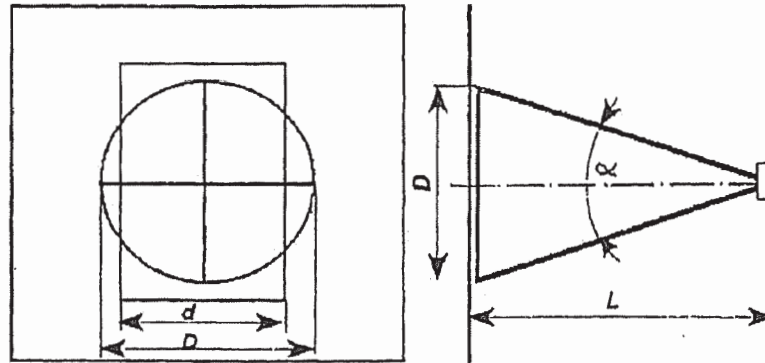

$$\frac{d}{D} \geq 0.9$$

$\alpha$  - 限制視角  
 L - 距離，m  
 D - 視域直徑，m

$$D = 2L \cdot \tan \frac{\alpha}{2}$$

3.3 對於長邊小於 1.57 倍短邊的窗子，只需一個熱通量計。

3.4 對於長邊大於 1.57 倍短邊的長方形窗子，需要附加通量計。通量計與窗子間的距離應調整到使通量計的視域範圍至少為窗子的 50%。但是通量計與窗子間的距離應不少於 0.5m 且不大於 2.5m。



圖

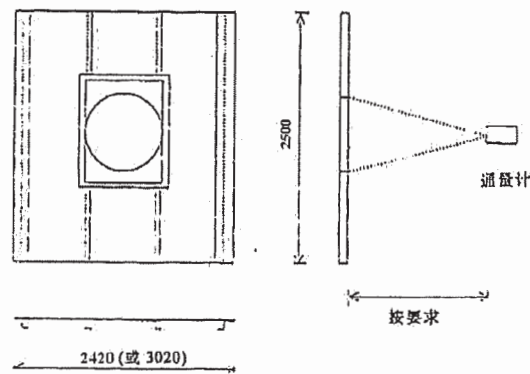

#### 4 分級標準

4.1 應測量出試驗的前 15 分鐘、前 30 分鐘和整個試驗期間(即“A”級邊界 60 分鐘、“B”級邊界 30 分鐘)的熱通量峰值 ( $E_w$ )。

4.2 把按第 4.1 款測量的熱通量峰值 ( $E_w$ ) 與表中的基準值 ( $E_c$ ) 相比較。

4.3 如果  $E_w$  小於  $E_c$ ，窗子可以裝在具有相應耐火級別的邊界上。

表 1—熱通量標準

| 耐火分隔等級 | 試驗開始後的<br>時間 | 熱通量<br>$E_c$ ( $\text{kW/m}^2$ ) |
|--------|--------------|----------------------------------|
| A-0    | 60 分鐘        | 56.5                             |
| A-15   | 15 分鐘        | 2.34                             |
|        | 60 分鐘        | 8.0                              |
| A-30   | 30 分鐘        | 2.34                             |
|        | 60 分鐘        | 6.4                              |
| A-60   | 60 分鐘        | 2.34                             |
| B-0    | 30 分鐘        | 36.9                             |

| 耐火分隔等級 | 試驗開始後的<br>時間 | 熱通量<br>$E_c$ (kW/m <sup>2</sup> ) |
|--------|--------------|-----------------------------------|
| B-15   | 15 分鐘        | 2.34                              |
|        | 30 分鐘        | 4.3                               |

## 附錄 2

### 連續“B”級分隔

#### 1 範圍

1.1 本附件規定了驗證襯板和天花板為“連續‘B’級襯板”和“連續‘B’天花板”及評估其整體結構為“連續‘B’級結構”的試驗程序。

1.2 本程序為選擇性要求。某些主管機關可以對連續“B”級分隔要求採用這一程序。

#### 2 試驗程序和評估

2.1 襯板、天花板及其結構應按第 A.754 (18) 號決議通過下述安排進行評估。

2.2 天花板應按第 A.754 (18) 號決議附件的第 2.8 款進行評估，但天花板應架在水平試驗爐上，使至少有 150mm 高的“B”級艙壁安放在試驗爐上，並將天花板通過實際上要採取的連接方法固定在這些部分艙壁上。此種天花板和連接方法應按 A.754 (18) 號決議對天花板的要求得到評估並應相應地被定為“連續‘B’（視情為 B-0 或 B-15）級天花板”。

2.3 可以認為按第 A.754 (18) 號決議被評估為“B”（視襯板試驗

情況為 B-0 或 B-15) 級的襯板與 “連續 ‘B’ (視情為 B-0 或 B-15) 級天花板” 和試驗中採用的連接方法 (見前第 2.2 段) 一起構成 “連續 ‘B’ (視情為 B-0 或 B-15) 級襯板, 無需進一步試驗。

2.4 應認為在 “A” 級甲板上安裝和由 “連續 ‘B’ (視情為 B-0 或 B-15) 級襯板” 和 “連續 ‘B’ (視情為 B-0 或 B-15) 級天花板” 構成的圍閉結構形成 “連續 ‘B’ 級結構”。

## 第 4 部分 – 耐火門控制系統試驗

### 1 適用範圍

如果要求防火門控制系統能夠在發生火災時工作，該系統應符合本部分的要求。

### 2 耐火試驗程序

防火門控制系統應按本部分附錄中所載的試驗程序進行試驗和評估。

### 3 附加要求

本附件第 1 部分也適用於防火門控制系統所使用的有關隔熱材料。

## 附錄

### 防火門控制系統耐火試驗程序

#### 1 通則

1.1 準備用於能夠在發生火災時工作的防火門的防火門控制系統應按本附錄所述的耐火試驗程序不依賴於其動力供應（氣動、液壓或電動）進行試驗。

1.2 耐火試驗應為原型試驗，應將全部控制系統放在一個具有第A.754（18）號決議規定尺寸的燃燒爐中進行。

1.3 要試驗的結構對於將在船上使用的結構應儘可能具有代表性，包括材料和裝配方式。

1.4 應對包括其關閉裝置的控制系統的功能進行試驗，即正常功能和緊急功能（如果要求的話），如果製造商把轉換功能作為一個設計基礎，則包括轉換功能。

#### 2 原型控制系統的性質

2.1 原型控制系統的安裝應完全符合廠家的安裝手冊。

2.2 原型控制系統應包括與關閉裝置連接的典型門裝置。為了試驗，應採用一個門模型。對於滑動門，模型門應在帶有原支撐和導向輪的原軌道上滑行。模型門應具有由該控制系統驅動的最大的重量。

2.3 對於氣動或液壓系統，促動器（汽缸）應具有試爐所能允許的最大長度。

### 3 原型控制系統的材料

#### 3.1 規格

在試驗以前，申請人應向試驗室提交試驗安排的圖紙和材料清單。

#### 3.2 控制測量

3.2.1 試驗室應選取所有其特性對原型控制系統的性能有重要作用的基準材料的樣品。

3.2.2 如果必要，應按第 1 部分對隔熱材料做不易燃性試驗。不要求樣品構造中使用的粘合劑具有不易燃性，但是，它們應具有低播焰性。

3.2.3 應確定每種隔熱材料的密度。礦物棉或任何類似的可壓縮材料的密度，應與標定厚度相關。

3.2.4 每種隔熱材料和材料組合在一起的厚度應通過一個適當的量規或卡尺來測量。

### 4 原型控制系統的調製

4.1 不必對原型控制系統（除隔熱外）進行調製。

4.2 如果結構中使用了隔熱材料，在隔熱材料未達到風乾狀態時不得對原型控制系統進行試驗。這種狀態被設計成在 23℃ 時環境空氣的相對濕度為 50% 的平衡狀態（恆重）。

只要不會改變構成材料的屬性，允許採用加速調製。高溫調製應低於材料的極限溫度。

## 5 原型控制系統的安裝

5.1 原型防火門控制系統和隔熱層（如果用來保護該系統或保護該系統的一部分）應架在艙壁板上，如圖 1 所示。

5.2 構芯應按照第 A.754 (18) 號決議第 5 節 “A” 級分隔的原則安裝在爐內。

5.3 應把門模型安置在爐內。裝控制系統和門模型的構芯應不設門開口。但是，允許對控制系統的解脫裝置設小的開口。

## 6 原型控制系統的檢驗

### 6.1 符合

試驗室應驗證原型控制系統與圖紙和申請者提供的裝配方法（見第 2 節）相符，並應在試驗開始前消除所有不符合的情況。

### 6.2 原型控制系統的操作

在試驗即將開始之前，試驗室應通過把門模型開啓至少 300mm 的距離來檢查系統的可操作性。

## 7 儀錶

爐和爐的儀錶應符合第 A.754 (18) 號決議附件第 7 節的要求。

## 8 試驗方法

### 8.1 試驗開始

在試驗開始前不超過 5 分鐘內，應檢查所有熱電偶記錄的初始溫度，以保證一致，並應記下數據值。對於變形應取得類似的數據值，並應記下原型控制系統的初始狀態。

試驗時，內部的初始平均溫度應為  $20\pm 10^{\circ}\text{C}$ ，並且與初始的環境溫度之差在  $5^{\circ}\text{C}$  以內。

## 8.2 爐控制

爐控制應符合第 A.754 (18) 號決議附件第 8.3 段的要求。

## 8.3 溫度、試驗時間和試驗期間的行為

8.3.1 平均爐溫應在 5 分鐘內升至  $200\pm 50^{\circ}\text{C}$ ，並穩定在該溫度上。這一溫度水平應一直保持到前 60 分鐘結束。然後，平均爐溫應按標準的時間－溫度曲線從  $200^{\circ}\text{C}$  升至  $945^{\circ}\text{C}$ 。

8.3.2 門控制機構的開關功能在從試驗開始起的 60 分鐘時間內應每隔 5 分鐘被啓動一次。

8.3.3 在平均爐溫為  $300^{\circ}\text{C}$  時，自動轉換裝置應將門控制系統與動力供應隔離開，並應至少在  $945^{\circ}\text{C}$  以內能使門保持關閉。

## 8.4 對原型控制系統的測量和觀察

對於氣動或液壓系統，對應該與認可的系統壓力相同的輸入壓力應予記錄。由於會出現高輸入壓力，在進行試驗時應採取必要的安全措施。

## 9 分級標準

9.1 在試驗的前 60 分鐘內，原型耐火控制系統不得失靈。

9.2 從試驗開始 60 分鐘後直到試驗結束，門應保持關閉。



## 10 試驗報告

試驗報告應包括所有與原型控制系統和耐火試驗有關的重要信息，包括以下具體項目：

- .1 試驗室名稱和試驗日期；
- .2 試驗申請人的姓名；
- .3 原型控制系統的生產商和在構造中使用的產品和部件的生產商的名稱，以及識別標誌和商品名；
- .4 原型控制系統的構造細節，包括部件的陳述、圖紙和主要細節。第 2 節所要求的所有細節都應列出。報告中的陳述和圖紙應儘實際可能以對原型控制系統進行檢驗時取得的信息為基礎。如果報告中沒有包括全部和詳盡的圖紙，則申請者的原型控制系統圖紙應由試驗室加以鑒定，並且至少有一份經過鑒定的圖紙副本應由試驗室保留；在這種情況下，應在報告中提及申請者的圖紙，同時指明對圖紙進行鑒定的方法；
- .5 所用材料與原型控制系統的耐火性能有關的全部特性和隔熱材料厚度和密度的測量數據；
- .6 關於試驗是按本附錄的要求進行的說明；如對規定的程序作過的任何變動（包括主管機關的任何特殊要求）：有關改動的明確說明；

- .7 試驗時在場的主管機關代表的姓名。如果沒有主管機關的代表目睹試驗，在報告中應以下述形式註明這種情況：
- “……（主管機關的名稱）……已被通知將進行本報告所詳述的試驗，但它認為不必派代表目睹試驗。”
- .8 有關壓力表或其他儀器位置的信息和試驗中所取得的數據表；
- .9 對原型控制系統在試驗期間重要行為的觀察和照片（如果有的話）；及
- .10 關於原型耐火門控制系統已經通過試驗並符合分級標準的聲明。



圖 1-安裝原型防火門控制系統的構芯

|     |   |       |    |   |      |
|-----|---|-------|----|---|------|
| D   | = | 門模型   | R  | = | 支撐滾柱 |
| DCU | = | 門控制裝置 | PS | = | 管系   |
| DT  | = | 門軌    | PG | = | 壓力計  |
| WF  | = | 焊固    | PP | = | 壓力管  |
| GT  | = | 導軌    | E  | = | 能    |
| CYL | = | 門液壓缸  | FW | = | 爐壁   |

## 第 5 部分 — 表面易燃性試驗

### 1 適用範圍

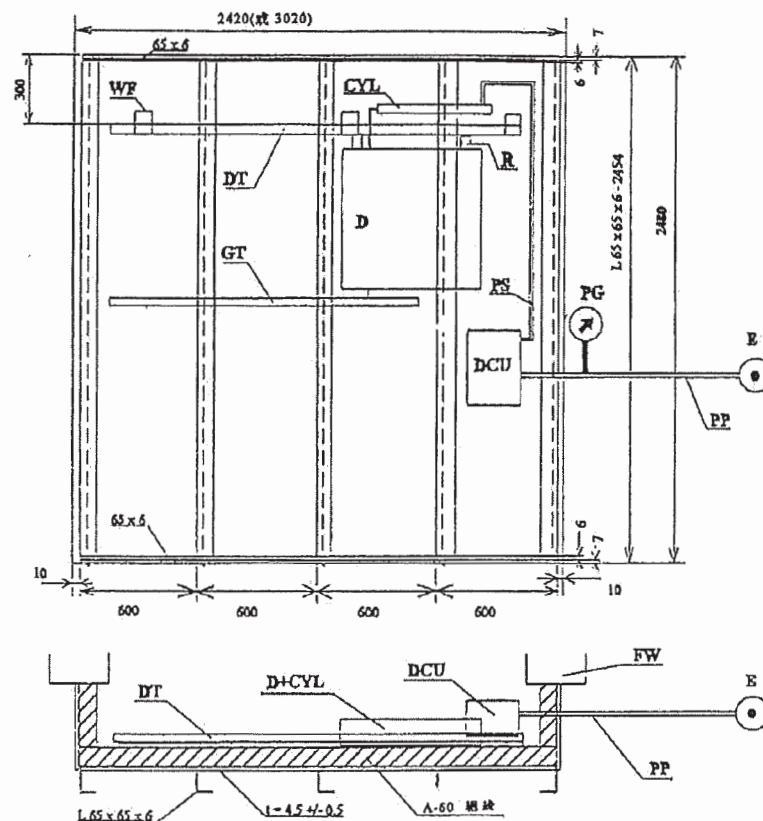
如果要求一種產品的表面具有低播焰性，則該產品應符合本部分的要求。

### 2 耐火試驗程序

2.1 表面材料應按第 A.653 (16) 號決議中規定的試驗程序進行試驗。就本部分言，第 A.653 (16) 號決議附件第 10 節中對地板覆層規定的總放熱值 (Qt) 應由  $\leq 2.0\text{MJ}$  取代。試驗可在 40 分鐘後終止。

2.2 在對艙壁、天花板和甲板的塗層材料和甲板底覆層 (甲板底覆層見本附件第 6 部分) 進行耐火試驗期間，有些樣品表現出不同的現象，引起對材料分級的困難。本部分的附錄對這種結果的統一解釋提供了指導。

### 3 附加要求

#### 3.1 艙壁和天花板及類似暴露表面的表面材料

如果對一種產品的最大總發熱值 (如  $45\text{MJ/m}^2$ ) 有要求，則建議採用國際標準化組織 1716:1973 標準中規定的方法確定總發熱值。

#### 3.2 地板覆層和甲板底覆層

3.2.1 甲板底覆層是地板結構的第一層，直接敷在甲板板材上面，包括所有主要塗層、防腐複合材料或對甲板板材提供保護或粘接的粘合劑。甲板板材以地板結構的其他層為地板覆層。

3.2.2 如果要求地板覆層具有低播焰性，則所有層都應符合第 5 部分的要求。如果地板覆層為多層結構，主管機關可以要求對地板覆層的每一層或多層組合進行試驗。地板覆層的單獨每一層，或多層組合（即試驗和認可只適用於這種組合）都應符合本部分的要求。在要求甲板底覆層不易點燃並置於地板覆層的下面時，甲板底覆層應符合第 6 部分的要求。在甲板底覆層也是暴露表面時，應符合本部分的要求。甲板板材上的底漆或類似的薄漆膜不需符合第 6 部分的上述要求。

### 3.3 易燃通風管道

3.3.1 如果要求易燃通風管道的材料具有低播焰性，則第 A.653（16）號決議的襯板和天花板塗層的表面易燃性試驗程序和標準應適用於這些導管。如果這些導管使用了均質材料，應對導管的外表面進行試驗，對於複合材料的導管，應試驗其內外兩側。

### 3.4 供冷系統的隔熱材料

如果要求供冷系統的蒸汽阻凝層和與隔熱材料一起使用的粘合劑及管道配件隔熱材料的暴露表面具有低播焰性，則第 A.653（16）號決議的襯板和天花板塗層的表面易燃性試驗程序和標準應適用這些暴露表面。

### 3.5 其他參考

本附件第 2 部分也適用於表面材料。

## 附 錄

### 對結果的解釋

#### 評估試樣的異常行為

(見本部分第 2.2 款)

| 異常行為                            | 分級指南                                                                |
|---------------------------------|---------------------------------------------------------------------|
| 1 閃光、無持續火焰                      | 報告火焰最終進展和時間及閃光是否在中心線。依據此數據分類。                                       |
| 2 爆裂，無閃光或火焰                     | 視材料為通過了試驗。                                                          |
| 3 表面上快速閃光繼而為穩定的火焰進展             | 報告兩個火焰前沿的結果，但依據兩個燃燒系統的四個試驗參數每者中最壞性能來分級。                             |
| 4 試樣或飾面熔化，並滴落，無火焰               | 報告行為和樣品上的進展程度。                                                      |
| 5 爆裂，試樣暴露部分有火焰                  | 報告爆炸情況，並依據火焰發展情況分級，不論火焰在中心線上面或下面                                    |
| 6 試樣或飾面熔化，燃燒並滴落                 | 無論標準如何均應拒絕該材料。對地板敷料，不超過 10 滴可接受。                                    |
| 7 引燃火焰熄滅                        | 報告發生的情況，數據作廢並重試。                                                    |
| 8 試驗和重新插入假試樣後的熱釋放信號仍高於或低於初始平衡水平 | 數據作廢，穩定設備，重新試驗。                                                     |
| 9 在地毯或非剛性試樣上的非常短的點火延遲           | 可能由疊堆在支架表面上的延伸引起，減小與引燃火焰的距離，使用第 A.653 (16) 號決議附件 8.1.1 段中程序要求的墊片重做。 |
| 10 試樣斷裂並掉下支撐架                   | 報告行為，但依據第 A.653 (16) 號決議附件第 8.3.2 段中有和沒有樣品限制器的最差性能進行分級。             |
| 11 自試樣、粘接劑或連接劑上噴射出很多可燃高溫分解氣體    | 拒絕該材料。                                                              |
| 12 試樣邊緣仍有小的火焰                   | 報告行為，並在暴露的試樣表面火焰熄                                                   |

減 3 分鐘後終止試驗。

## 第 6 部分 – 甲板底覆層試驗

### 1 適用範圍

- 1.1 要求不能迅速點燃的甲板底覆層應符合本章要求。
- 1.2 對於確定甲板的哪些層應作為甲板覆層以及其中哪些層應作為甲板底覆層來試驗，見第 5 部分 3.2 段。

### 2 耐火試驗程序

- 2.1 甲板底覆層應按照第 A.687 (17) 號決議中規定的燃燒試驗程序進行試驗和評估。
- 2.2 該試驗應在燃燒 40 分鐘後終止。

### 3 附加要求

本附件第 2 部分也適用於甲板底覆層。

## 第 7 部分－垂直支撐的紡織物和薄膜片試驗

### 1 適用範圍

當要求帷幔、窗簾或其他有支撐的紡織物品的抗火焰蔓延能力不低於質量為  $0.8\text{kg/m}^2$  的毛織品時，它們應符合本部分要求。

### 2 耐火試驗程序

垂向支撐的紡織品和薄膜應按經第 A.563 (14) 號決議修正的第 A.471 (XII) 號決議中規定的耐火試驗程序進行試驗和評估。

### 3 附加要求

應使用最終產品試樣（經着色處理）進行試驗。在只有顏色改變的情況下，不需做新的試驗。但在基本產品或處理程序改變時，應要求做新的試驗。



## 第八部分 – 罩面家具試驗

### 1 適用範圍

當要求罩面家具具有抗點燃和抗火焰蔓延特性時，這種罩面家具應符合本部分要求。

### 2 耐火試驗程序

罩面家具應按第 A.652 (16) 號決議中規定的耐火試驗程序進行試驗和評定。

### 3 附加要求

試驗時應使用最終產品的試樣（即經過着色處理）。在只有顏色改變時，不需做新的試驗。但在基本的產品或處理程序改變時，應做新的試驗。

## 第九部分－床上用品試驗

### 1 適用範圍

當要求床上用品具有抗點燃和抗火焰蔓延的特性時，該床上用品應滿足本部分要求。

### 2 耐火試驗程序

床上用品應按照第 A.688 (17) 號決議中規定的耐火試驗程序進行試驗和評估。

### 3 附加要求

試驗應使用最終產品的試樣（即經過着色處理）。在只有顏色改變時，不需要做新的試驗。但在基本的產品或處理程序改變時，需要做新的試驗。

## 附件 2

### 未經試驗和/或認可便可安裝的產品

#### 總 則

本附件所列產品和產品組一般被認為具有下面規定的耐火安全特性，它們可以不用按本規則規定的對產品的特殊安全性能的特別耐火試驗程序進行試驗和認可便可予以安裝。

下列各款的編號與附件 1 中規定的對應試驗要求部分的編號相同。

#### 1 不易燃性材料

僅由玻璃和混凝土製做的產品、陶瓷製品、天然石頭、磚塊、普通金屬和金屬合金一般才被認為是不易燃性材料，因此它們可以不經過試驗和認可便可安裝使用。

#### 2 在火中既不產生大量煙霧也不產生有毒物品的材料

2.1 不燃性材料一般被認為符合附件 1 第 2 部分的要求，不需做進一步試驗。

2.2 總放熱量 ( $Q_t$ ) 不超過 0.2MJ 和最高放熱率 ( $q_p$ ) 不超過 1.0kw (兩數值依據附件 1 第 5 部分或第 A.653 (16) 號決議來確定) 的表面材料和甲板底覆層一般被認為滿足附件 1 第 2 部分的要求，不需做進一步試驗。

#### 3 “A”、 “B” 及 “F” 級分隔

### 3.1 下列產品不經過試驗或認可便可以安裝：

| 分級      | 產品描述                                                                 |
|---------|----------------------------------------------------------------------|
| A-0 級艙壁 | 鋼質艙壁具有不小於下述最小尺寸：<br>— 板厚：4mm<br>— 間隔為 600mm 的 60x60x5mm 加強肋板或等效結構    |
| A-0 級甲板 | 具有不小於下述最小尺寸的鋼質甲板：<br>— 板厚度：4mm<br>— 間隔為 600mm 的 95x65x7mm 加強肋板或等效結構。 |

3.2 儘管有上述第 3.1 條規定，用於 A、B 和 F 級分隔並要求具有某些其他規定特性（如不易燃性、低播火特性等）的材料應符合本規則附件 1 適當部分或第 8 節和附件 3 的要求。

## 4 防火門控制系統

（無項目）

## 5 低播火性表面

5.1 不易燃性材料被認為符合附件 1 第 5 部分要求。但應對使用方法和固定方式（如膠水）給予充分考慮。

5.2 根據附件 1 第 6 部分定為不易點燃的甲板基層塗料被認為符合附件 1 第 5 部分對底層塗料的要求。

**6 甲板基層塗料**

不易燃性材料被認為符合附件 1 第 6 部分要求。但應對使用方法和固定方式給予充分考慮。

**7 垂直支撐的紡織品和薄膜**

(無項目)

**8 罩面用家具**

(無項目)

**9 床上用品**

(無項目)

### 附件 3

#### 其他耐火試驗程序的使用

主管機關可以使用非附件 1 中者的下列試驗程序：

- .1 對於大會以前通過的耐火試驗程序，截止日期列於下表；  
和
- .2 關於某一主管機關應用的其他即定的試驗程序和接受標準，試驗截止日期為 1998 年 12 月 31 日，認可截止日期為 2003 年 12 月 31 日。

| 產品<br>(附件 1 所及部分)                  | 試驗程序                                         | 試驗過期日            | 認可過期日            |
|------------------------------------|----------------------------------------------|------------------|------------------|
| 不燃性材料<br>(第 1 部分)                  | 第 A.472 (XII) 號決議                            | 1998 年 12 月 31 日 | 2003 年 12 月 31 日 |
|                                    | 第 A.270 (VIII) 號決議                           | 1997 年 7 月 1 日   | 2002 年 7 月 1 日   |
| 不產生大量煙塵也不<br>產生有毒物品的材料<br>(第 2 部分) | —                                            | —                | —                |
| A、B 和 F 級分隔<br>(第 3 部分)            | 第 A.517 (13) *號決議                            | 1998 年 12 月 31 日 | 2003 年 12 月 31 日 |
|                                    | 第 A.215 (VII) 號決議修正的<br>第 A.163 (ES.IV) *號決議 | 1997 年 7 月 1 日   | 2002 年 7 月 1 日   |
|                                    | 第 A.163 (ES.IV) *號決議                         | 1997 年 7 月 1 日   | 2002 年 7 月 1 日   |
| 耐火門控制系統<br>(第 4 部分)                | —                                            | —                | —                |
| 表面材料<br>(第 5 部分)                   | A.564 (14) 號決議                               | 1998 年 12 月 31 日 | 2003 年 12 月 31 日 |
|                                    | A.516 (13) 號決議                               | 1998 年 12 月 31 日 | 2003 年 12 月 31 日 |
| 甲板基層敷料                             | A.214 (VII) 號決議                              | 1998 年 12 月 31 日 | 2003 年 12 月 31 日 |

|                    |                 |             |             |
|--------------------|-----------------|-------------|-------------|
| (第6部分)             |                 |             |             |
| 垂直支撐的紡織品<br>(第7部分) | A.471 (XII) 號決議 | 1998年12月31日 | 2003年12月31日 |
| 裝飾家具<br>(第8部分)     | –               | –           | –           |
| 床上用品<br>(第9部分)     | –               | –           | –           |

\*註：可用 140°C 的最大平均溫升代替在第 A.163 (ES.IV) 號決議  
和第 A.517 (13) 的接受標準中的 139°C。

**RESOLUTION MSC.61(67)**  
**(adopted on 5 December 1996)**

**ADOPTION OF THE INTERNATIONAL CODE FOR APPLICATION  
OF FIRE TEST PROCEDURES**

THE MARITIME SAFETY COMMITTEE,

RECALLING Article 28(b) of the Convention on the International Maritime Organization concerning the functions of the Committee,

RECOGNIZING the need to provide a mandatory application of fire test procedures required by chapter II-2 of the International Convention for the Safety of Life at Sea (SOLAS), 1974, as amended,

NOTING resolution MSC.57(67) by which it adopted, *inter alia*, amendments to chapter II-2 of the SOLAS Convention to make the provisions of the International Code for Application of Fire Test Procedures (FTP Code) mandatory under that Convention on or after 1 July 1998,

HAVING CONSIDERED, at its sixty-seventh session, the text of the proposed FTP Code,

1. ADOPTS the International Code for Application of Fire Test Procedures (FTP Code) the text of which is set out in the Annex to the present resolution;
2. NOTES that under the amendments to chapter II-2 of the SOLAS Convention, amendments to the FTP Code should be adopted, brought into force and shall take effect in accordance with the provisions of article VIII of that Convention concerning the amendments procedures applicable to the annex to the Convention other than chapter I;
3. REQUESTS the Secretary-General to transmit certified copies of the present resolution and the text of the FTP Code contained in the Annex to all Contracting Governments to the Convention;
4. FURTHER REQUESTS the Secretary-General to transmit copies of this resolution and the Annex to all Members of the Organization which are not Contracting Governments to the Convention.



## ANNEX

## INTERNATIONAL CODE FOR APPLICATION OF FIRE TEST PROCEDURES

## Contents

- 1 Scope
- 2 Application
- 3 Definitions
- 4 Testing
  - 4.1 Fire test procedures
  - 4.2 Testing laboratories
  - 4.3 Test reports
- 5 Approval
  - 5.1 General
  - 5.2 Type approval
  - 5.3 Case-by-case approval
- 6 Products which may be installed without testing and/or approval
- 7 Use of equivalents and modern technology
- 8 Period of grace for other test procedures
- 9 List of references
- Annex 1 Fire test procedures
  - Preamble**
  - Part 1 Non-combustibility test
  - Part 2 Smoke and toxicity test
  - Part 3 Test for "A", "B" and "F" class divisions
    - Appendix 1 - Thermal radiation test supplement to fire resistance tests for windows in "A", "B" and "F" class divisions
    - Appendix 2 - Continuous "B" class divisions
  - Part 4 Test for fire door control systems
    - Appendix - Fire test procedure for fire door control systems
  - Part 5 Test for surface flammability
    - Appendix - Interpretation of results
  - Part 6 Test for primary deck coverings
  - Part 7 Test for vertically supported textiles and films
  - Part 8 Test for upholstered furniture
  - Part 9 Test for bedding components
- Annex 2 Products which may be installed without testing and/or approval
- Annex 3 Use of other fire test procedures

## INTERNATIONAL CODE FOR APPLICATION OF FIRE TEST PROCEDURES

### 1 SCOPE

1.1 This Code is intended for use by the Administration and the competent authority of the flag State when approving products for installation in ships flying the flag of the flag State in accordance with the fire safety requirements of the International Convention for the Safety of Life at Sea, 1974, as amended.

1.2 This Code shall be used by the testing laboratories when testing and evaluating products under this Code.

### 2 APPLICATION

2.1 This Code is applicable for the products which are required to be tested, evaluated and approved in accordance with the Fire Test Procedures Code as referenced in the Convention.

2.2 Where reference to the Code is indicated in the Convention by the terminology "... in accordance with the Fire Test Procedures Code" the subject product shall be tested in accordance with the applicable fire test procedure or procedures as referred to in paragraph 4.1.

2.3 Where reference is only made to a product's fire performance in the Convention using such terminology as "... and their exposed surfaces shall have low flame spread characteristics", the subject product shall be tested in accordance with the applicable fire test procedure or procedures as referred to in paragraph 4.1.

### 3 DEFINITIONS

3.1 "Fire Test Procedures Code" means the International Code for Application of Fire Test Procedures as defined in chapter II-2 of the Convention, as amended.

3.2 "Test expiry date" means the last date on which the given test procedure may be used to test and subsequently approve any product under the Convention.

3.3 "Approval expiry date" means the last date on which the subsequent approval is valid as proof of meeting the fire safety requirements of the Convention.

3.4 "Administration" means the Government of the State whose flag the ship is entitled to fly.

3.5 "Competent authority" means an organization authorized by the Administration to perform functions required by this Code.

3.6 "Laboratory recognized by the Administration" means a testing laboratory which is acceptable to the Administration concerned. Other testing laboratories may be recognized on a case-by-case basis for specific approvals as agreed upon by the Administration concerned.

3.7 "Convention" means the International Convention for the Safety of Life at Sea, 1974, as amended.

3.8 "Standard fire test" means a test in which specimens are exposed in a test furnace to temperatures corresponding approximately to the standard time-temperature curve.

3.9 "Standard time-temperature curve" means the time-temperature curve defined by the formula:

$$T = 345 \log_{10}(8t + 1) + 20$$

where:

T is the average furnace temperature (°C)  
t is the time (minutes).

## 4 TESTING

### 4.1 Fire test procedures

4.1.1 Annex 1 of this Code presents the required test procedures which shall be used in testing products as a basis for approval (including renewal of approval), except as provided in section 8.

4.1.2 The test procedures identify the test methods and the acceptance and classification criteria.

### 4.2 Testing laboratories

4.2.1 The tests shall be carried out in testing laboratories recognized by the Administrations concerned.

4.2.2 When recognizing a laboratory, the Administration shall consider the following criteria:

- .1 that the laboratory is engaged, as a regular part of its business, in performing inspections and tests that are the same as, or similar to, the tests as described in the applicable part;
- .2 that the laboratory has access to the apparatus, facilities, personnel, and calibrated instruments necessary to perform these tests and inspections; and
- .3 that the laboratory is not owned or controlled by a manufacturer, vendor or supplier of the product being tested.

4.2.3 The testing laboratory shall use a quality control system audited by the competent authority.

### 4.3 Test reports

4.3.1 The test procedures state the required contents of the test reports.

4.3.2 In general, a test report is the property of the sponsor of the test.

## 5 APPROVAL

### 5.1 General

5.1.1 The Administration shall approve products in accordance with their established approval procedures by using the type approval procedure (see paragraph 5.2) or the case-by-case approval (see paragraph 5.3).

5.1.2 The Administration may authorize competent authorities to issue approvals on their behalf.

5.1.3 An applicant who seeks approval shall have the legal right to use the test reports on which the application is based (see paragraph 4.3.2).

5.1.4 The Administration may require that the approved products are provided with special approval markings.

5.1.5 The approval shall be valid when the product is installed on board a ship. If a product is approved when manufactured, but the approval expires before the product is installed on the ship, the product may be installed as approved material, provided that the criteria have not changed since the expiry date of the approval certificate.

5.1.6 The application for approval shall be sought from the Administration or competent authority. The application shall contain at least the following:

- .1 the name and address of the applicant and of the manufacturer;
- .2 the name or trade name of the product;
- .3 the specific qualities for which approval is sought;
- .4 drawings or descriptions of the assembly and materials of the product as well as instructions, where applicable, for its installation and use; and
- .5 a report on the fire test(s).

5.1.7 Any significant alteration to a product shall make the relevant approval to cease to be valid. To obtain a new approval, the product shall be retested.

## **5.2 Type approval**

5.2.1 The type approval certificates shall be issued and renewed on basis of the test reports of the applicable fire tests (see section 4).

5.2.2 The Administration shall require that the manufacturers have a quality control system audited by a competent authority to ensure continuous compliance with the type approval conditions. Alternatively, the Administration may use final product verification procedures where the compliance with the type approval certificate is verified by a competent authority before the product is installed on board ships.

5.2.3 The type approval certificates shall be valid no more than 5 years from the date of issue.

5.2.4 Type approval certificates shall include at least the following:

- .1 identification (name or trade name and description) of the product;
- .2 classification and any restrictions in the use of the product;
- .3 name and address of the manufacturer and applicant;
- .4 test method(s) used in test(s);

- .5 identification of the test report(s) and applicable statements (including date of issue, possible file number and the name and address of the testing laboratory);
- .6 date of issue and possible number of the type approval certificate;
- .7 expiration date of the certificate; and
- .8 name of the issuing body (competent authority) and, if applicable, authorization.

5.2.5 In general, the type approved products may be installed for their intended use on board ships flying the flag of the approving Administration.

### **5.3 Case-by-case approval**

5.3.1 The case-by-case approval means approval where a product is approved for installation on board a specific ship without using a type approval certificate.

5.3.2 The Administration may approve products using the applicable test procedures for specific ship applications without issuing a type approval certificate. The case-by-case approval is only valid for the specific ship.

## **6 PRODUCTS WHICH MAY BE INSTALLED WITHOUT TESTING AND/OR APPROVAL**

Annex 2 of this Code specifies the groups of products, which (if any) are considered to comply with the specific fire safety regulations of the Convention and which may be installed without testing and/or approval.

## **7 USE OF EQUIVALENTS AND MODERN TECHNOLOGY**

7.1 To allow modern technology and development of products, the Administration may approve products to be installed on board ships based on tests and verifications not specifically mentioned in this Code but considered by the Administration to be equivalent with the applicable fire safety requirements of the Convention.

7.2 The Administration shall inform the Organization of approvals referenced to in paragraph 7.1 in accordance with regulation I/5 of the Convention and follow the documentation procedures as outlined below:

- .1 in the case of new and unconventional products, a written analysis as to why the existing test method(s) cannot be used to test this specific product;
- .2 a written analysis showing how the proposed alternative test procedure will prove performance as required by the Convention; and
- .3 a written analysis comparing the proposed alternative test procedure to the required procedure in the Code.

## 8 PERIOD OF GRACE FOR OTHER TEST PROCEDURES

8.1 The newest test procedures adopted by the Organization are considered being the most suitable for demonstrating that the products concerned comply with the applicable fire safety requirements of the Convention.

8.2 Notwithstanding what is said elsewhere in this Code, the Administration may use established test procedures and acceptance criteria, other than those in annex 1 to this Code, when approving products to comply with the fire safety requirements of the Convention to allow a practicable period of grace for the testing laboratories to obtain testing equipment, for the industry to re-test their products and for the Administrations to provide the necessary new certification. For such other test procedures and acceptance criteria the test expiry dates and the approval expiry dates are given in annex 3 to this Code.

## 9 LIST OF REFERENCES

The following IMO Assembly resolutions and ISO standards are referred to in parts 1 to 9 of annex 1 to the Code:

- .1 resolution A.471(XII) - "Recommendation on test method for determining the resistance to flame of vertically supported textiles and films";
- .2 resolution A.563(14) - "Amendments to the Recommendation on test method for determining the resistance to flame of vertically supported textiles and films (resolution A.471(XII))";
- .3 resolution A.652(16) - "Recommendation on fire test procedures for upholstered furniture";
- .4 resolution A.653(16) - "Recommendation on improved fire test procedures for surface flammability of bulkhead, ceiling and deck finish materials";
- .5 resolution A.687(17) - "Fire test procedures for ignitability of primary deck coverings";
- .6 resolution A.688(17) - "Fire test procedures for ignitability of bedding components";
- .7 resolution A.753(18) - "Guidelines for the application of plastic pipes on ships";
- .8 resolution A.754(18) - "Recommendation on fire resistance tests for "A", "B" and "F" class divisions";
- .9 ISO 1182:1990 - "Fire test - Building materials - Non-combustibility test";
- .10 ISO 1716:1973 - "Building materials - Determination of calorific potential"; and
- .11 ISO 5659:1994 - "Plastics - Smoke generation, Part 2 Determination of optical density by a single chamber test".

## ANNEX 1

**FIRE TEST PROCEDURES****Preamble**

1 This annex contains the fire test procedures which shall be used for verifying that the products comply with the applicable requirements. For other test procedures provisions in paragraph 8.2 of, and annex 3 to, the Code shall apply.

2 Reference to the test procedures of this annex shall be made (e.g., in the test report and in the type approval certificate) by referring to the applicable part number or numbers as follows:

Example: Where a primary deck covering has been tested in accordance with parts 2 and 6 of annex 1, the reference shall be "IMO FTPC Parts 2 and 6".

3 Some products or their components are required to be tested in accordance with more than one test procedure. For this purpose, references to other parts are given in some parts of this annex. Such references are here for information only, and the applicable guidance shall be sought in the relevant requirements of the Convention.

4 For products which may be installed without testing and/or approval, annex 2 to the Code is referred.

**PART 1 - NON-COMBUSTIBILITY TEST****1 Application**

1.1 Where a material is required to be non-combustible, it shall be determined in accordance with this part.

1.2 If a material passes the test as specified in section 2, it shall be considered as "non-combustible" even if it consists of a mixture of inorganic and organic substances.

**2 Fire test procedure**

2.1 The non-combustibility shall be verified in accordance with the test procedure in the standard ISO 1182:1990 except that instead of Annex A "Criteria for evaluation" of this standard all the following criteria shall be satisfied:

- .1 the average furnace thermocouple temperature rise as calculated in 8.1.2 of ISO 1182 does not exceed 30°C;
- .2 the average surface thermocouple temperature rise as calculated in 8.1.2 of ISO 1182 does not exceed 30°C;
- .3 the mean duration of sustained flaming as calculated in 8.2.2 of ISO 1182 does not exceed 10 s; and
- .4 the average mass loss as calculated in 8.3 of ISO 1182 does not exceed 50%.

2.2 The test report shall include the following information:

- .1 name of testing body;
- .2 name of manufacturer of the material;
- .3 date of supply of the materials and of tests;
- .4 name or identification of the material;
- .5 description of the material;
- .6 density of the material;
- .7 description of the specimens;
- .8 test method;
- .9 test results including all observations;
- .10 designation of the material according to the test criteria specified in paragraph 2.1 above.



**PART 2 - SMOKE AND TOXICITY TEST****1 Application**

Where a material is required not to be capable of producing excessive quantities of smoke and toxic products or not to give rise to toxic hazards at elevated temperatures, the material shall comply with this part.

**2 Fire test procedure****2.1 General**

Smoke generation tests shall be conducted in accordance with standard ISO 5659:1994, Part 2 and additional test procedures as described in this part of the Code. To carry out the tests in accordance with this standard, modifications of the arrangements and procedures to the ISO standard shall be made, if necessary.

**2.2 Test specimen**

Preparation of test specimen shall be in accordance with the practice outlined in resolutions A.653(16), A.687(17) and A.753(18). In the case of cables, only specimens of those with maximum insulation thickness need be tested.

**2.3 Test conditions**

Irradiance to the specimen during the test shall be kept constant. Three specimens shall be tested under each of the following conditions:

- .1 irradiance of 25 kW/m<sup>2</sup> in the presence of pilot flame;
- .2 irradiance of 25 kW/m<sup>2</sup> in the absence of pilot flame; and
- .3 irradiance of 50 kW/m<sup>2</sup> in the absence of pilot flame.

**2.4 Duration of tests**

The test shall be carried out for at least 10 min. If the minimum light transmittance value has not been reached during the 10-minute exposure, the test shall be continued for a further 10-minute period.

## 2.5 Test results

2.5.1 Specific optical density of smoke (Ds) as defined below shall be recorded during the test period at least every 5 s:

$$D_s = (V/(A*L)) * \log_{10}(I_0/I)$$

where:

V = total volume of the chamber (m<sup>3</sup>)

A = exposed area of the specimen (m<sup>2</sup>)

L = optical length (m) of smoke measurement

I<sub>0</sub> = light intensity before the test

I = light intensity during the test (after absorption by the smoke).

2.5.2 When making toxicity measurements, the sampling of fumes shall be made during the testing of the second or the third specimen at each test condition, from the geometrical centre of the chamber within 3 min of the time when the maximum specific optical density of smoke is reached. The concentration of each toxic gas shall be determined as ppm in the chamber volume.

## 2.6 Classification criteria

### 2.6.1 Smoke

An average (Dm) of the maximum of Ds of three tests at each test condition shall be calculated.

- .1 for materials used as surface of bulkheads, linings or ceilings, the Dm shall not exceed 200 in any test condition;
- .2 for materials used as primary deck covering, the Dm shall not exceed 400 in any test condition;
- .3 for materials used as floor covering, the Dm shall not exceed 500 in any test condition;  
and
- .4 for plastic pipes and electric cables, the Dm shall not exceed 400 in any test condition.

### 2.6.2 Toxicity

The gas concentration measured at each test condition shall not exceed the following limits:

|                 |          |                 |         |
|-----------------|----------|-----------------|---------|
| CO              | 1450 ppm | HBr             | 600 ppm |
| HCl             | 600 ppm  | HCN             | 140 ppm |
| HF              | 600 ppm  | SO <sub>2</sub> | 120 ppm |
| NO <sub>x</sub> | 350 ppm  |                 |         |

## 2.7 Test report

A test report shall contain the following information:

- .1 type of the material, i.e. surface finish, floor covering, primary deck covering, pipes, etc;
- .2 trade name of the material;
- .3 description of the material;
- .4 construction of the specimen;
- .5 name and address of the manufacturer of the material;
- .6 Dm at each heating and ignition condition;
- .7 concentrations of toxic gases in ppm, if applicable;
- .8 judgement according to paragraph 2.6;
- .9 name and address of the testing laboratory; and
- .10 date of testing

## 3 Additional requirements

- 3.1 Part 5 of this annex is also applicable to paints, floor coverings, varnishes and other finishes used on exposed interior surfaces.
- 3.2 Part 6 of this annex is also applicable to the primary deck coverings.

## **PART 3 - TEST FOR "A", "B" AND "F" CLASS DIVISIONS**

### **1 Application**

Where products (such as decks, bulkheads, doors, ceilings, linings, windows, fire dampers, pipe penetrations and cable transits) are required to be "A" or "B" or "F" class divisions, they shall comply with this part.

### **2 Fire test procedure**

2.1 The products shall be tested and evaluated in accordance with the fire test procedure specified in resolution A.754(18). This contains test procedures also for windows, fire dampers and pipe and duct penetrations in its appendices.

#### **2.2 Specimen sizes**

2.2.1 For the purpose of this Code, the first sentence of paragraphs 2.1.1, 2.4.1 and 2.7.1 of the annex to resolution A.754(18) is replaced by the following:

"The minimum overall dimensions of test specimen, including the perimeter details at the top, bottom and vertical edges, are 2,440 mm width and 2,500 mm height, except that the minimum overall dimensions of 2,440 mm in height and 4.65 m<sup>2</sup> in the exposed surface of the test specimen may be used in testing up to 31 December 1998. The approval expiry date is 31 December 2003 for approvals based on tests with such smaller test specimen."

2.2.2 For the purpose of this Code, the first sentence of paragraphs 2.2.1, 2.5.1 and 2.8.1 of the annex to resolution A.754(18) is replaced by the following:

"The minimum overall dimensions of test specimen, including the perimeter details at all the edges, are 2,440 mm width and 3,040 mm length, except that the minimum overall dimensions of 2,440 mm in length and 4.65 m<sup>2</sup> in the exposed surface of the test specimen may be used in testing up to 31 December 1998. The approval expiry date is 31 December 2003 for approvals based on tests with such smaller test specimen."

#### **2.2.3 The specimen sizes shall be given in the test reports**

2.3 Where thermal radiation through windows is required to be limited, the window assembly may be tested and evaluated in accordance with appendix 1 of this part.

2.4 Where ceilings or linings are required to be continuous "B" class ceilings or linings they may be tested and evaluated in accordance with appendix 2 of this part.

### **3 Additional requirements**

3.1 The integrity of class "B" constructions shall be achieved with non-combustible materials. Adhesives used in the construction of the specimen are not required to be non-combustible; however, for the purpose of this Code, they shall have low flame-spread characteristics.

3.2 Materials placed at "B" class panel joints for avoiding vibration or noise transmission shall be of low flame spread characteristics and fire tested with "B" class divisions along which they are used. However, such materials shall be non-combustible if they are necessary to support the non-combustible "B" class structure or to achieve the required integrity.

3.3 Doors and shutters, which are fitted above the bulkhead deck and which are required to meet both fire protection and watertight requirements, shall comply with the fire protection requirements as required in the Convention, for the divisions where they are installed. The watertight doors fitted below the bulkhead deck are not required to be insulated.

#### **4 Other references**

4.1 The non-combustibility of materials used in "A" and "B" class divisions shall be verified in accordance with part 1.

4.2 Where combustible veneers are allowed to be provided in "A" and "B" class divisions, the low flame spread characteristics of such veneers, if required, shall be verified in accordance with part 5.

## APPENDIX 1

### THERMAL RADIATION TEST SUPPLEMENT TO FIRE RESISTANCE TESTS FOR WINDOWS IN "A", "B" AND "F" CLASS DIVISIONS

#### 1 Scope

1.1 This appendix specifies a procedure for measuring heat flux through windows as a basis for characterizing their ability to limit the heat radiation in order to prevent the spread of fire and to enable escape routes to pass near the windows.

1.2 This procedure is an optional requirement and may be requested by some Administrations for windows in specific areas of a ship.

#### 2 Test procedure

2.1 The window should be tested in accordance with resolution A.754(18) using the additional instrumentation as described below.

2.2 The term "window" includes windows, side scuttles and any other glazed opening provided for light transmission or vision purposes in a fire resistant division. The term "fire resistant division" includes bulkheads and doors.

#### 3 Additional instrumentation

3.1 Additional instrumentation consists of a restricted-view total-heat fluxmeter calibrated with the restricted view to indicate incident heat flux. The fluxmeter should be water-cooled and capable of measuring heat flux 0 to 60 kW/m<sup>2</sup>. The fluxmeter should be calibrated at least once a year against a standard device.

3.2 The fluxmeter should be placed perpendicular to the centre of the window being tested, and in a position such that the centre of the fluxmeter's view coincides with the centre of the window (see the figure). The fluxmeter should be located at a distance greater than 0.5 m from the window, such that the view of the fluxmeter just includes part of the frame. However, the fluxmeter should not be located more than 2.5 m from the window. The dimension of the boundary and window frame seen by the fluxmeter, which remains outside the window should not exceed 10% of the total width seen by the fluxmeter on the surface of the sample. It should be calculated on the basis of restricted view angle of the fluxmeter and its distance to the sample surface.

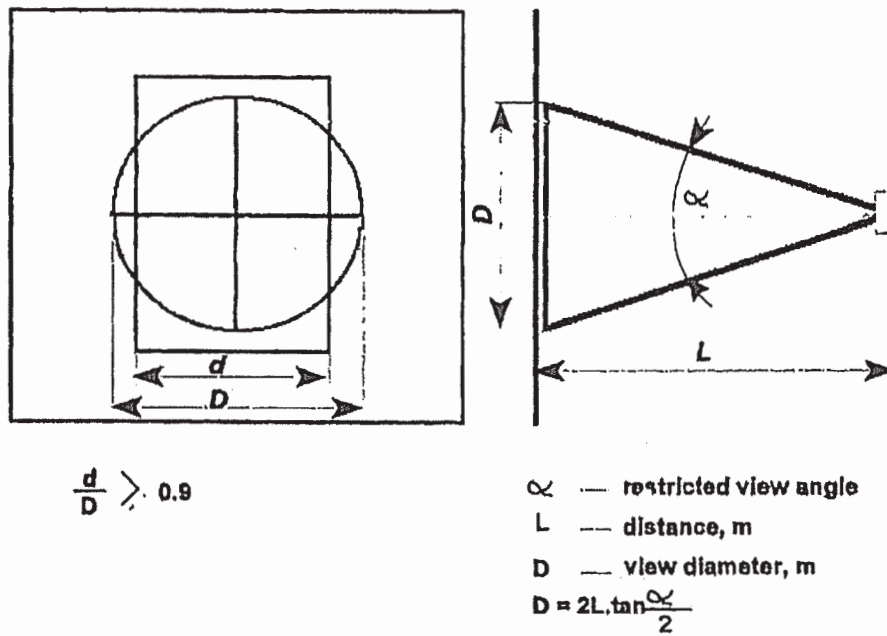

3.3 For windows whose greater dimension is less than 1.57 times the smaller dimension, only one fluxmeter is needed.

3.4 For oblong windows whose greater dimension is more than 1.57 times the smaller dimension, additional fluxmeters should be provided. The distance of the fluxmeters from the window should be adjusted such that the fluxmeters' view covers at least 50% of the window. However, the fluxmeters should not be located less than 0.5 m nor more than 2.5 m from the window.

Figure

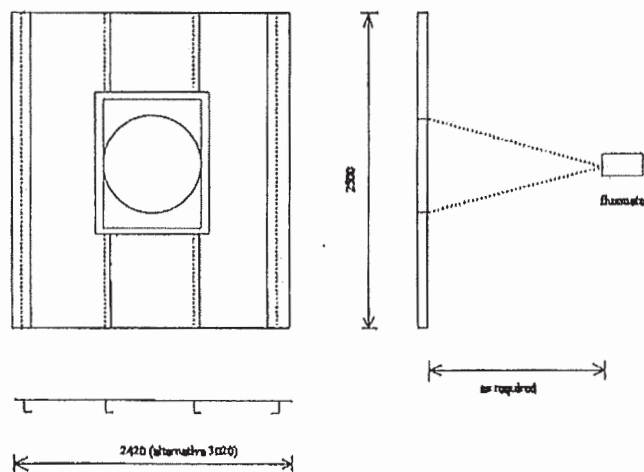

#### 4 Classification criteria

4.1 The peak heat flux ( $E_w$ ) should be measured for the first 15 min of the test, for the first 30 min of the test, and for the entire duration of the test (i.e. 60 min for class "A" and 30 min for class "B" boundaries).

4.2 The peak heat fluxes ( $E_w$ ) measured in accordance with paragraph 4.1 should be compared against the reference value ( $E_c$ ) from the table.

4.3 If ( $E_w$ ) is less than ( $E_c$ ), the window is acceptable for installation in a boundary of the corresponding fire resistant classification.

Table 1 - Criteria for heat flux

| Fire resistant division classification | Time period from beginning of test to | Heat flux $E_c$ (kW/m <sup>2</sup> ) |
|----------------------------------------|---------------------------------------|--------------------------------------|
| A-0                                    | 60 minutes                            | 56.5                                 |
| A-15                                   | 15 minutes                            | 2.34                                 |
|                                        | 60 minutes                            | 8.0                                  |
| A-30                                   | 30 minutes                            | 2.34                                 |
|                                        | 60 minutes                            | 6.4                                  |
| A-60                                   | 60 minutes                            | 2.34                                 |
| B-0                                    | 30 minutes                            | 36.9                                 |
| B-15                                   | 15 minutes                            | 2.34                                 |
|                                        | 30 minutes                            | 4.3                                  |



**APPENDIX 2****CONTINUOUS "B" CLASS DIVISIONS****1 Scope**

1.1 This appendix specifies the procedure for testing linings and ceilings for verifying that they are "continuous 'B' class linings" and "continuous 'B' class ceilings" and for evaluating full constructions to be "continuous 'B' class constructions".

1.2 This procedure is an optional requirement and may be requested by some Administrations for continuous "B" class divisions.

**2 Test procedure and evaluation**

2.1 The linings, ceilings and constructions should be evaluated in accordance with resolution A.754(18) using the arrangements described below.

2.2 The ceilings should be tested in accordance with paragraph 2.8 of the annex to resolution A.754(18) except that the ceiling should be mounted on the horizontal furnace so that at least 150 mm high "B" class bulkheads are mounted on the furnace and the ceiling is fixed to these partial bulkheads by using the joining method as is intended to be used in practice. Such ceilings and the joining methods should be evaluated as required for ceilings in accordance with resolution A.754(18) and accordingly they should be classified as "continuous 'B' (B-0 or B-15, as applicable) class ceilings".

2.3 A lining which has been evaluated in accordance with resolution A.754(18) to be a "B" (B-0 or B-15, as applicable on basis of the lining test) class lining may be considered forming "continuous 'B' (B-0 or B-15, as applicable) class lining" in conjunction with a "continuous 'B' (B-0 or B-15, as applicable) class ceiling" and with the joining method used in the test (see paragraph 2.2 above) without further testing the lining.

2.4 An enclosed construction installed on an "A" class deck and formed by "continuous 'B' (B-0 or B-15, as applicable) class linings" and "continuous 'B' (B-0 or B-15, as applicable) class ceiling" should be considered forming "continuous 'B' class construction".

**PART 4 - TEST FOR FIRE DOOR CONTROL SYSTEMS****1 Application**

Where a control system of fire doors is required to be able to operate in case of fire, the system shall comply with this part.

**2 Fire test procedure**

The fire door control systems shall be tested and evaluated in accordance with the test procedure presented in the appendix to this part.

**3 Additional requirements**

Part 1 of this annex is also applicable to insulation materials used in connection with a fire door control system.

**APPENDIX****FIRE TEST PROCEDURE FOR FIRE DOOR CONTROL SYSTEMS****1 General**

1.1 Fire door control systems which are intended to be used for fire doors capable of operating in case of fire shall be tested in accordance with the fire test procedure described in this appendix independent of its power supply (pneumatical, hydraulic or electrical).

1.2 The fire tests shall be a prototype test and be carried out with the complete control system in a furnace dimensioned according to resolution A.754(18).

1.3 The construction to be tested shall be, as far as practicable, representative of that to be used on board ships, including the materials and method of assembly.

1.4 The functions of the control system including its closing mechanism shall be tested, i.e. normal functions of and, if required, emergency function, including switchover functions, if this is a basis of the manufacturer's design. The required kind of installation and functions shall be evident from a detailed function description.

**2 Nature of prototype control systems**

2.1 The installation of the prototype control system shall fully comply with the manufacturer's installation manual.

2.2 The prototype control system shall include a typical door arrangement connected to the closing mechanism. For the purpose of the test a door model shall be used. In case of sliding doors, the model door shall run in original door tracks with original supporting and guide rollers. The model door shall have the weight of the largest door to be actuated by this control system.

2.3 In case of pneumatic or hydraulic systems, the actuator (cylinder) shall have the maximum length allowed by the furnace.

**3 Materials for prototype control systems****3.1 Specifications**

Prior to the test, drawings and the list of materials of the test arrangement shall be submitted to the laboratory by the applicant.

**3.2 Control measurements**

3.2.1 The testing laboratory shall take reference specimens of all those materials whose characteristics are important to the performance of the prototype control system (excluding steel and equivalent material).

3.2.2 If necessary, non-combustibility tests of insulation material in accordance with part 1 shall be conducted. Adhesives used in the construction of the specimen are not required to be non-combustible, however, they shall have low flame-spread characteristics.

3.2.3 The density of each insulation material shall be determined. The density of mineral wool or any similar compressible material shall be related to the nominal thickness.

3.2.4 The thickness of each insulation material and combination of materials shall be measured by using a suitable gauge or calipers.

#### **4 Conditioning of the prototype control systems**

4.1 Conditioning of the prototype control system (except insulation) is not necessary.

4.2 If insulation material is used in the construction, the prototype control system shall not be tested until the insulation has reached an air dry condition. This condition is designed as an equilibrium (constant weight) with an ambient atmosphere of 50% relative humidity at 23°C.

Accelerated conditioning is permissible provided the method does not alter the properties of component materials. High temperature conditioning shall be below temperatures critical for the materials.

#### **5 Mounting of the prototype control systems**

5.1 The prototype fire door control system and the insulation, if used for protection of the system or parts of it, shall be mounted at the bulkhead plate as shown in figure 1.

5.2 The structural core shall be mounted at the furnace in accordance with the principles for 'A' class divisions in paragraph 5 of resolution A.754(18).

5.3 The door model shall be arranged within the furnace. The structural core to which the system and the door model are fitted shall have no door opening. However, small openings for the release mechanism of the control systems are allowed.

#### **6 Examination of the prototype control systems**

6.1 Conformity

The laboratory shall verify the conformity of the prototype control system with the drawings and method of assembly provided by the applicant (see section 2), and any area of discrepancy shall be resolved prior to commencement of the test.

6.2 Operation of the prototype control system

Immediately prior to the test, the laboratory shall check the operability of the system by opening the door model by a distance of at least 300 mm. The door model shall then be closed.

## 7 Instrumentation

The furnace and the instrumentation of the furnace shall be in accordance with section 7 of the annex to resolution A.754(18).

## 8 Method of test

### 8.1 Commencement of test

Not more than 5 min before the commencement of the test, the initial temperatures recorded by all thermocouples shall be checked to ensure consistency and the datum values shall be noted. Similar datum values shall be obtained for deformation, and initial condition of the prototype control system shall be noted.

At the time of the test, the initial average internal temperature shall be  $20 \pm 10^\circ\text{C}$  and shall be within  $5^\circ\text{C}$  of the initial ambient temperature.

### 8.2 Furnace control

The furnace control shall be in accordance with paragraph 8.3 of the annex to resolution A.754(18)

### 8.3 Temperatures, duration of testing and actions during test

8.3.1 The average furnace temperature shall be increased and stabilized at  $200 \pm 50^\circ\text{C}$  within 5 min and kept at the level of  $200 \pm 50^\circ\text{C}$  up to the end of the first 60 min. Then the average furnace temperature shall be increased according to the standard time-temperature curve beginning with the level of  $200^\circ\text{C}$  up to  $945^\circ\text{C}$ .

8.3.2 The opening and closing function of the door control mechanism shall be activated every 5 min from the beginning of the test for the duration of 60 min.

8.3.3 The automatic switchover shall isolate the door control system from the power supply at the average furnace temperature of  $300^\circ\text{C}$  and shall be able to keep the door closed at least up to  $945^\circ\text{C}$ .

### 8.4 Measurements and observations on the prototype control system

In case of pneumatic or hydraulic systems, the input pressure which shall be identical with the approved system pressure shall be recorded. Due to a high input pressure, necessary safety precautions shall be taken when the test is carried out.

## 9 Classification criteria

9.1 During the first 60 min of the test, a prototype fire door control system shall not fail.

9.2 During the period from the end of the first 60 min until the end of the test, the door shall remain closed.

## 10 Test report

The test report shall include all important information relevant to the prototype control system and the fire test, including the following specific items:

- .1 the name of the testing laboratory and the test date;
- .2 the name of the applicant for the test;
- .3 the name of the manufacturer of the prototype control system and of the products and components used in the construction, together with identification marks and trade names;
- .4 the constructional details of the prototype control system, including description and drawings and principal details of components. All the details requested in section 2 shall be given. The description and the drawings which are included in the test report shall, as far as practicable, be based on information derived from a survey of the prototype control system. When full and detailed drawings are not included in the report, then the applicant's drawing(s) of the prototype control system shall be authenticated by the laboratory and at least one copy of the authenticated drawing(s) shall be retained by the laboratory; in this case reference to the applicant's drawing(s) shall be given in the report together with a statement indicating the method of endorsing the drawings;
- .5 all the properties of materials used that have a bearing on the fire performance of the prototype control system together with measurements of thickness and density of the insulation material(s);
- .6 a statement that the test has been conducted in accordance with the requirements of this Appendix and if any deviations have been made to the prescribed procedures (including any special requirements of the Administration), a clear statement of the deviations;
- .7 the name of the representative of the Administration present at the test. When the test is not witnessed by a representative of the Administration, a note to this effect shall be made in the report in the following form:

“The ..... (name of the Administration) ... was notified of the intention to conduct the test detailed in this report and did not consider it necessary to send a representative to witness it.”;
- .8 information concerning the location of the pressure gauges or other devices together with tabulated data obtained during the test;
- .9 observations of significant behaviour of the prototype control system during test and photographs, if any; and
- .10 a statement that the prototype fire door control system has passed the test and complies with the classification criteria.

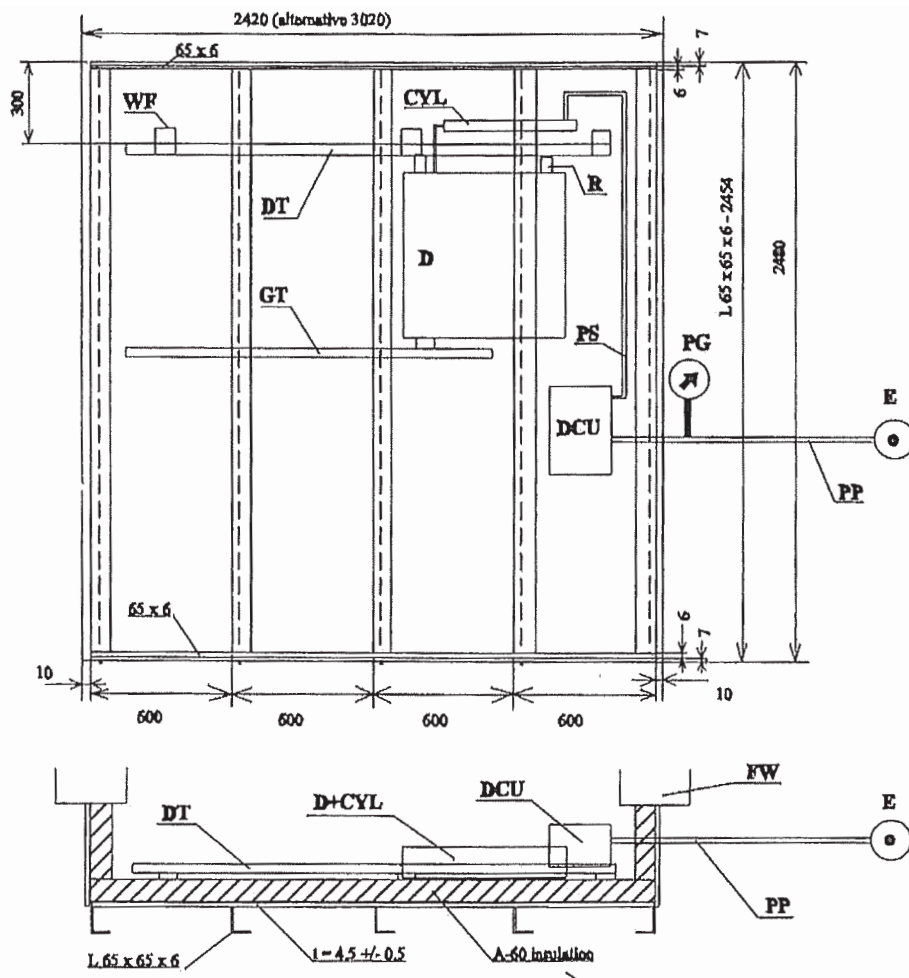

Figure 1 - Structural core for fitting the prototype fire door control system.

- |                          |                        |
|--------------------------|------------------------|
| D = door model,          | R = supporting roller, |
| DCU = door control unit, | PS = piping system,    |
| DT = door track,         | PG = pressure gauge,   |
| WF = weld fastening,     | PP = pressure pipe,    |
| GT = guide track,        | E = energy,            |
| CYL = door cylinder,     | FW = furnace wall.     |

## **PART 5 - TEST FOR SURFACE FLAMMABILITY**

### **1 Application**

Where a product is required to have a surface with low flame-spread characteristics, the product shall comply with this part.

### **2 Fire test procedure**

2.1 The surface materials shall be tested and evaluated in accordance with the test procedure specified in resolution A.653(16). For the purpose of this part, the total heat release value ( $Q_t$ ) for floor coverings given in section 10 of the Annex to resolution A.653(16) is replaced by  $\leq 2.0$  MJ. The test may be terminated after 40 min.

2.2 During fire tests for bulkhead, ceiling and deck finish materials and primary deck coverings (see part 6 of this annex for primary deck coverings), there are those specimens which exhibit various phenomena which cause difficulties in classification of the materials. Appendix to this part provides guidance on the uniform interpretation of such results.

### **3 Additional requirements**

#### **3.1 Surface materials for bulkheads and ceilings and similar exposed surfaces**

In case there is a requirement of maximum gross calorific value (e.g. 45 MJ/m<sup>2</sup>) for a product, the method specified in standard ISO 1716: 1973 is recommended for determining the gross calorific value.

#### **3.2 Floor coverings and primary deck coverings**

3.2.1 A primary deck covering is the first layer of a floor construction which is applied directly on top of the deck plating and is inclusive of any primary coat, anti-corrosive compound or adhesive which is necessary to provide protection or adhesion to the deck plating. Other layers in the floor construction above the deck plating are floor coverings.

3.2.2 Where a floor covering is required to be low flame-spread, all layers shall comply with part 5. If the floor covering has a multilayer construction, the Administration may require the tests to be conducted for each layer or for combinations of some layers of the floor coverings. Each layer separately, or a combination of layers (i.e. the test and approval are applicable only to this combination), of the floor covering shall comply with this part. When a primary deck covering is required to be not readily ignitable and is placed below a floor covering, the primary deck covering shall comply with part 6. When the primary deck covering is also the exposed surface, it shall comply with this part. Primer or similar thin film of paint on deck plating need not comply with the above requirements of part 6.

#### **3.3 Combustible ventilation ducts**

3.3.1 Where combustible ventilation ducts are required to be of material which has low flame-spread characteristics, the surface flammability test procedure and criteria for lining and ceiling finishes according to resolution A.653(16) shall be applied for such ducts. In case homogeneous materials are used for the ducts, the test shall apply to outside surface of the duct, whilst both sides of the ducts of composite materials shall be tested.



**3.4 Insulation materials for cold service systems**

Where the exposed surfaces of vapour barriers and adhesives used in conjunction with insulation, as well as insulation of pipe fittings, for cold service systems are required to have low flame-spread characteristics, the surface flammability test procedure and criteria for linings and ceilings according to resolution A.653(16) shall be applied for such exposed surfaces.

**3.5 Other references**

Part 2 of this annex is also applicable to surface materials.

## APPENDIX

### INTERPRETATION OF RESULTS Evaluating unusual test specimen behaviour (see paragraph 2.2 of this part)

| Unusual behaviour                                                                                                                      | Guidance on classification                                                                                                                                                                 |
|----------------------------------------------------------------------------------------------------------------------------------------|--------------------------------------------------------------------------------------------------------------------------------------------------------------------------------------------|
| 1 Flashing, no steady flame                                                                                                            | Report furthest progress of flame and time, and whether or not flash is on centerline. Classify on basis of the data.                                                                      |
| 2 Explosive spalling, no flashing or flame                                                                                             | Accept material as passing test.                                                                                                                                                           |
| 3 Rapid flash over surface, later steady flame progress                                                                                | Report result for both flame fronts but classify on basis of worst performance for each of the four test parameters in the two burning regimes.                                            |
| 4 Specimen or veneer melts and drips off, no flame                                                                                     | Report behaviour and extent of advance on specimen.                                                                                                                                        |
| 5 Explosive spalling, and flame on exposed part of specimen                                                                            | Report explosions and classify on basis of flame progress irrespective of whether above or below centerline.                                                                               |
| 6 Specimen or veneer melts, burns, and drips off                                                                                       | Reject material regardless of criteria. For floor covering, no more than 10 burning drops are acceptable.                                                                                  |
| 7 Pilot flame extinguished                                                                                                             | Report occurrence, reject data and repeat test.                                                                                                                                            |
| 8 Heat release signal after test and re-insertion of dummy specimen remains at a higher or lower level than initial stabilizing level. | Reject data and stabilize the equipment, then repeat test.                                                                                                                                 |
| 9 Very short ignition delay on carpets or non-rigid specimens                                                                          | Could be caused by pile extension above holder surface, reducing space to pilot flame. Repeat with shims as required by procedure in paragraph 8.1.1 of the Annex to resolution A.653(16). |

|    |                                                                                           |                                                                                                                                                           |
|----|-------------------------------------------------------------------------------------------|-----------------------------------------------------------------------------------------------------------------------------------------------------------|
| 10 | Specimen breaks up, and falls out of holder                                               | Report behaviour, but classify on basis of worst performance with and without specimen restraint in paragraph 8.3.2 of the Annex to resolution A.653(16). |
| 11 | Substantial jetting combustible pyrolysis gases from specimen, adhesive or bonding agents | Reject material.                                                                                                                                          |
| 12 | Small flame remaining along the edge of specimen                                          | Report behaviour and terminate the test 3 min after flaming on exposed surface of specimen ceased.                                                        |

**PART 6 - TEST FOR PRIMARY DECK COVERINGS****1 Application**

1.1 Where the primary deck coverings are required to be not readily ignitable, they shall comply with this part.

1.2 For determining which layers on the deck shall be tested as floor coverings and which of them shall be tested as primary deck coverings, see paragraph 3.2 of part 5.

**2 Fire test procedure**

2.1 The primary deck coverings shall be tested and evaluated in accordance with the fire test procedure specified in resolution A.687(17):

2.2 The test shall be terminated after 40 min.

**3 Additional requirements**

Part 2 of this annex 1 is also applicable to primary deck coverings.

**PART 7 - TEST FOR VERTICALLY SUPPORTED TEXTILES AND FILMS****1 Application**

Where draperies, curtains and other supported textile materials are required to have qualities of resistance to the propagation of flame not inferior to those of wool of mass  $0.8 \text{ kg/m}^2$ , they shall comply with this part.

**2 Fire test procedure**

The vertically supported textiles and films shall be tested and evaluated in accordance with the fire test procedure specified in resolution A.471(XII) as amended by resolution A.563(14).

**3 Additional requirements**

The tests shall be made by using specimens of the final product (e.g. with colour treatment). In cases where only the colours change, a new test is not necessary. However, in cases where the basis product or the treatment procedure change, a new test is required.

**PART 8 - TEST FOR UPHOLSTERED FURNITURE****1 Application**

Where upholstered furniture are required to have qualities of resistance to the ignition and propagation of flame, the upholstered furniture shall comply with this part.

**2 Fire test procedure**

The upholstered furniture shall be tested and evaluated in accordance with the fire test procedure specified in resolution A.652(16).

**3 Additional requirements**

The tests shall be made by using specimens of the final product (e.g. with colour treatment). In cases where only the colours change, a new test is not necessary. However, in cases where the basis product or the treatment procedure change, a new test is required.

**PART 9 - TEST FOR BEDDING COMPONENTS****1 Application**

Where bedding components are required to have qualities of resistance to the ignition and propagation of flame, the bedding components shall comply with this part.

**2 Fire test procedure**

The bedding components shall be tested and evaluated in accordance with the fire test procedure specified in resolution A.688(17).

**3 Additional requirements**

The tests shall be made by using specimens of the final product (e.g. with colour treatment). In cases where only the colours change, a new test is not necessary. However, in cases where the basis product or the treatment procedure change, a new test is required.

## ANNEX 2

**PRODUCTS WHICH MAY BE INSTALLED WITHOUT TESTING  
AND/OR APPROVAL**

**General**

In general, the products and product groups listed in this annex are considered to have the fire safety characteristics specified below and they may be installed without testing according to and without approval on basis of the specific fire test procedures in this Code for the specific safety characteristics of the product.

The paragraphs below are numbered with the same part number in which the corresponding testing requirements are specified in annex 1.

**1 Non-combustible materials**

In general, products made only of glass, concrete, ceramic products, natural stone, masonry units, common metals and metal alloys are considered being non-combustible and they may be installed without testing and approval.

**2 Materials not generating excessive quantities of smoke nor toxic products in fire**

2.1 In general, non-combustible materials are considered to comply with the requirements of part 2 of annex 1 without further testing.

2.2 In general, surface materials and primary deck coverings with both the total heat release ( $Q_t$ ) of not more than 0.2 MJ and the peak heat release rate ( $q_p$ ) of not more than 1.0 kW (both values determined in accordance with part 5 of annex 1 or in accordance with resolution A.653(16) are considered to comply with the requirements of part 2 of annex 1 without further testing.

**3 "A", "B" and "F" class divisions**

3.1 The following products may be installed without testing or approval:

| <b>Classification</b> | <b>Product description</b>                                                                                                                                                                                                                       |
|-----------------------|--------------------------------------------------------------------------------------------------------------------------------------------------------------------------------------------------------------------------------------------------|
| Class A-0 bulkhead    | A steel bulkhead with dimensions not less than the minimum dimensions given below; <ul style="list-style-type: none"> <li>- thickness of plating: 4 mm</li> <li>- stiffeners 60 x 60 x 5 mm spaced at 600 mm or structural equivalent</li> </ul> |



Class A-0 deck

A steel deck with dimensions not less than the minimum dimensions given below:

- thickness of plating: 4 mm
- stiffeners 95 x 65 x 7 mm spaced at 600 mm or structural equivalent.

3.2 Notwithstanding the provisions in 3.1 above, the materials which are used in "A", "B" and "F" class divisions and which are required to have certain other specified characteristics (e.g. non-combustibility, low flame-spread characteristics, etc.) shall comply with the appropriate parts of annex 1 or section 8 and annex 3, of this Code.

**4 Fire door control systems**  
(no entries)

**5 Low flame-spread surfaces**

5.1 Non-combustible materials are considered to comply with the requirements of part 5 of annex 1. However, due consideration shall be given to the method of application and fixing (e.g. glue).

5.2 Primary deck coverings classified as not readily ignitable in accordance with part 6 of annex 1 are considered to comply with the requirements of part 5 of annex 1 for floor coverings.

**6 Primary deck coverings**

Non-combustible materials are considered to comply with the requirements of part 6 of annex 1. However, due consideration shall be given to the method of application and fixing.

**7 Vertically supported textiles and films**  
(no entries)

**8 Upholstered furniture**  
(no entries)

**9 Bedding components**  
(no entries)

## ANNEX 3

## USE OF OTHER FIRE TEST PROCEDURES

Administrations may use test procedures other than those referred to in annex 1 as follows:

- .1 for fire test procedures previously adopted by the Assembly, the expiry dates are given in the table below; and
- .2 for other established test procedures and acceptance criteria applied by an Administration, the test expiry date is 31.12.1998 and the approval expiry date is 31.12.2003.

| Products<br>(reference part in annex 1)                                                  | Test procedure                                                    | Test<br>expiry date | Approval<br>expiry date |
|------------------------------------------------------------------------------------------|-------------------------------------------------------------------|---------------------|-------------------------|
| Non-combustible materials<br>(part 1)                                                    | Resolution A.472(XII)                                             | 31.12.1998          | 31.12.2003              |
|                                                                                          | Resolution A.270(VIII)                                            | 1.7.1997            | 1.7.2002                |
| Materials not generating excessive<br>quantities of smoke nor toxic products<br>(part 2) | -                                                                 | -                   | -                       |
| A, B and F class divisions<br>(part 3)                                                   | Resolution A.517(13)*                                             | 31.12.1998          | 31.12.2003              |
|                                                                                          | Resolution A.163(ES.IV)* as<br>corrected by Resolution A.215(VII) | 1.7.1997            | 1.7.2002                |
|                                                                                          | Resolution A.163(ES.IV)*                                          | 1.7.1997            | 1.7.2002                |
| Fire door control systems<br>(part 4)                                                    | -                                                                 | -                   | -                       |
| Surface materials<br>(part 5)                                                            | Resolution A.564(14)                                              | 31.12.1998          | 31.12.2003              |
|                                                                                          | Resolution A.516(13)                                              | 31.12.1998          | 31.12.2003              |
| Primary deck coverings<br>(part 6)                                                       | Resolution A.214(VII)                                             | 31.12.1998          | 31.12.2003              |
| Vertically supported textiles<br>(part 7)                                                | Resolution A.471(XII)                                             | 31.12.1998          | 31.12.2003              |
| Upholstered furniture<br>(part 8)                                                        | -                                                                 | -                   | -                       |
| Bedding components<br>(part 9)                                                           | -                                                                 | -                   | -                       |

\*The maximum average temperature rise of 140°C may be used instead of 139°C in the acceptance criteria in resolutions A.163(ES.IV) and A.517(13).